

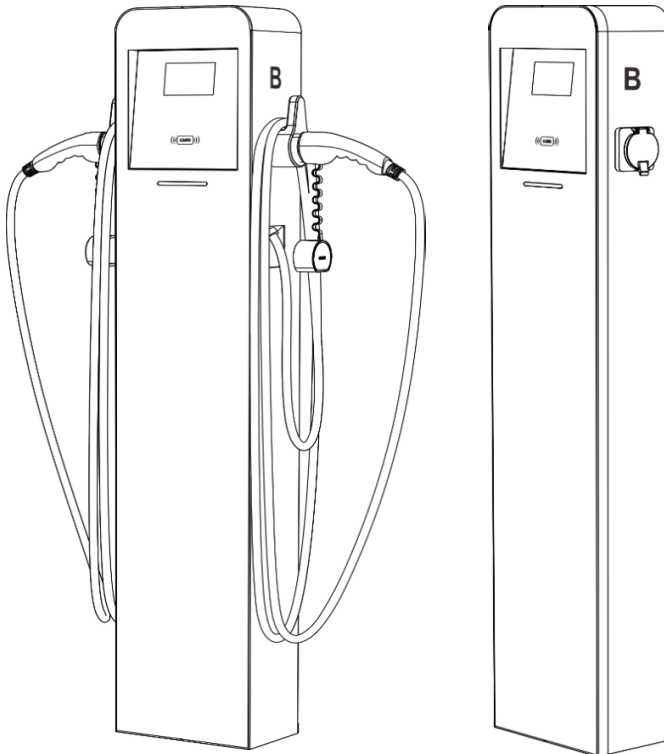

Twin Pedestal Floor Series

BK1 BK2 BK3 BK4 BK5

User manual



CONTENT

Warranty

1 Safety and Warning

2 Introduction

2.1 Product Technical Specifications

2.2 External Structure

2.3 Package Contents

3 Configuration and Operation

3.1 Installation Preparation

3.2 Installation Process

3 Configuration and Operation

3.1 Power-on Checking

3.2 Start and stop charging station BK1/BK2/BK3 by your charge card

3.3 Server and WiFi address configuration

3.4 Start and stop charging station BK1/BK2/BK3 by APP

4 Set up and update

4.1 Mode setting for maximum charging current

4.2 Firmware version upgrade (by SD card)

4.3 Firmware version upgrade (by online)

5 Troubleshooting

5.1 Indicator Status

5.2 Fault Code and Resolution (LCD display)

Warranty

warrants that products supplied to customer pursuant to this agreement/contract shall be of merchantable quality and shall meet all applicable safety standards and free from any defect of design, material and workmanship within the warranty period. The warranty period is twenty-four (24) months since from the delivery date. warranty does not cover damages resulting from inappropriate storage, incorrect installation, improper operation or bad environment beyond environmental requirement.

Customer gives notice in writing within a period of ten (10) days after customer has discovered that some or all products do not comply with the warranty as set out in this warranty. Customer shall provide necessary assistance to for failure detection, gives response within a reasonable time of 48 hours. shall analyze the fault reason and provide technical instruction for customer to repair products.

Customer repairs products and applies for free spare parts from in case replacements are required. A written claim report about fault description, serial number of products, photos of products and applied spare parts must be sent to for verification. shall not accept the claim if modifications or reworking have been performed to products without consent. Spare parts are offered for free within the warranty period. Beyond warranty period, spare parts are offered at customer's cost.

Faulted parts replaced by customer shall be well stored and packaged with markings of fault description for further disposal by. The faulted parts after repair and test can be treated as spare part to customer.

No local service is provided for free and charges service fee for local service according the following standards: USD100 (USD One Hundred Only) per person per day plus the actual travel costs and material costs. A mutual agreement should be reached before offering local service.

Except as set forth herein, provides no other warranty, whether express or implied. The warranty applies only to products which are supplied by and are used out of Mainland china.

1 Safety and Warning

Save these instructions. Read all instruction before installing or using the charger.

- 1) Keep the charger away from explosive or flammable materials, chemicals, vapors and other hazard objects.
- 2) Keep the charger socket clean and dry. If it gets dirty, please wipe it with clean dry cloth.
- 3) Touching the socket core is strictly forbidden when power on.
- 4) Do not use the charger in case of any device defects, crack, abrasion, bare leakage and so on. Please contact the professional personnel if any of these conditions occurs.
- 5) Do not attempt to disassemble, repair, refit the charger. If necessary, please contact the professional personnel. Improper operation will result in device damage, electric leakage, etc.
- 6) In case any abnormal condition happens, please cut off all input and output power supplies immediately.
- 7) Please protect charging carefully from rain and lightening.
- 8) Keep children away from the charger.
- 9) During charging, do not drive the EV Charge only when the EV is stationary, for hybrid cars, charge only when the engine is switched off.
- 10) Our packaging materials are environmentally friendly and can be recycled. Please put the packaging in applicable containers to recycle it. Do not dispose of this device with the household waste. It should be taken to a suitable facility for recycling of electrical and electronic devices. For more detailed information about recycling of this device, please contact your local city/town council office or your household waste disposal service.



Warning



The input and output voltages of this device are high voltage, which threaten human life safety. Please strictly observe all warnings on the device and user manual. Unauthorized and non-professional service personnel are forbidden to remove the cover of this device.

2 Introduction

2.1 Product Technical Specifications

Model	ZECO32A2-BK1	ZECO40A2-BK2	ZECO48A2-BK3	ZECO60A2-BK4	ZECO80A2-BK5
Technical features					
Charging capacity	Up to 14KW (7KW*2)	Up to 22KW (11KW*2)	Up to 44KW (22KW*2)	Up to 28.8KW (14.4KW*2)	Up to 40KW (19.2KW*2)
Input/Output power	230VAC±20%- 50/60Hz- 32A*2-lphase	400VAC±20%- 50/60Hz- 40A*2-lphase	400VAC±20%- 50/60Hz- 48A*2-lphase	400VAC±20%- 50/60Hz- 60A*2-lphase	400VAC±20%- 50/60Hz- 80A*2-lphase
RCD	RCD function CCID20				
Standby power	< 50W				
Measuring accuracy	1%				
Energy Meter	ETL certified				
OCPP	OCPP1.6 Json (OCPP2.0 optional)				
Communication	WiFi/Ethernet/4G (Optional)				
User interface	LED/LCD(5inch)/RFID(mifare iso & IEC 14443A)				
Certificate	NEC 625, SAE J1772, UL 817, UL 991, UL 2231, UL 225, and UL 2594. UL 2231				
Charging Interface	SAE J1772 32A 5M*2	SAE J1772 40A 5M*2	SAE J1772 48A 5M*2	SAE J1772 60A 5M*2	SAE J1772 80A 5M*2
Special Protection	Over current protection, Residual current protection, Ground protection, Surge protection, Over/Under voltage protection, Over/Under frequency protection, Over/Under temperature protection				
Physical properties					
Warranty	2 years				
Protection	IP55(outdoor)				
Special Protection	Topple & fall down protection				
Cooling	Natural cooling				
Operating temperature	-30°C to +55°C				
Humidity	Max.95%(non-regulating)				
Product Dimensions	1500*300*180mm(L*W*H)				
Package Dimension	1600*360*210mm(L*W*H)				
Net Weight	48Kg				
Gross Weight	55Kg				



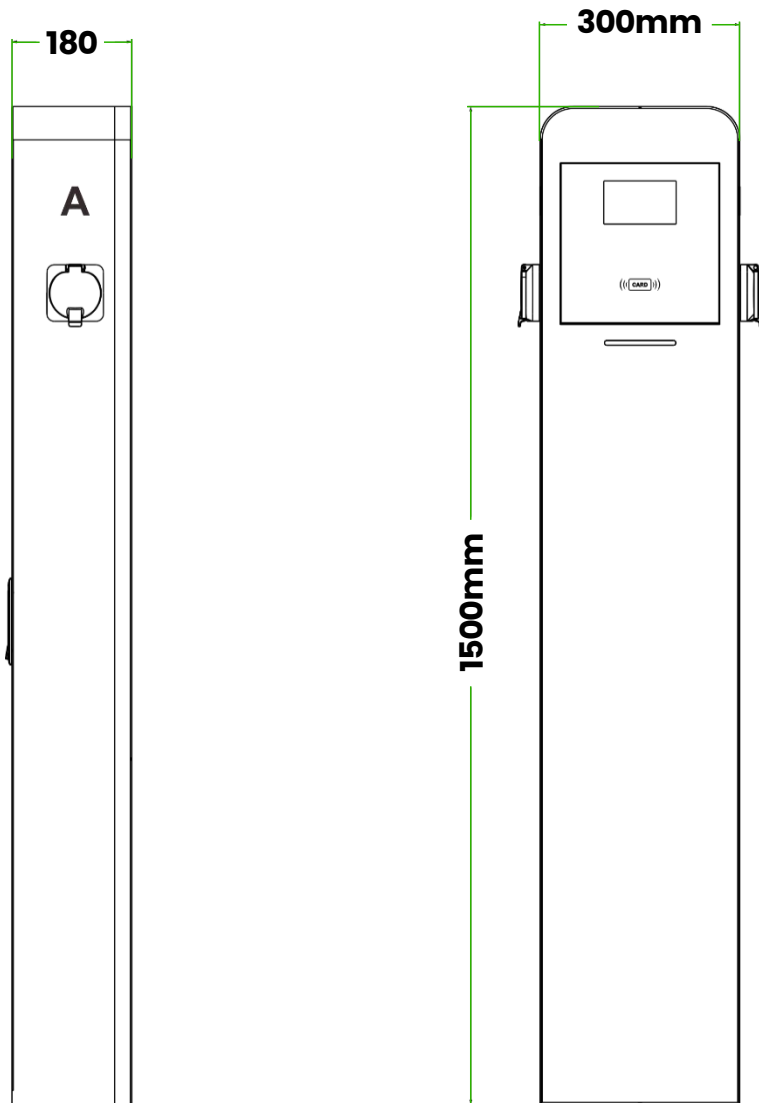

2.2 External Structure



2.2 External Structure

Unpack the product. Please check and verify following items after receiving the charger:





- Visual inspection on charger's external appearance. If there is any breakage or other damage, please notify the seller immediately.
- Check type and quantity of all accessories as follows. If there is a shortage in the quantity of any item or if any items are missing, please contact the seller at once.

	 Home EV Wallbox V1, V2, V3 Your asset		
	User Manual (x1)	M8 Screw nut (x4)	
			
F1/F2/F3 (x1)	RFID CARD (x2)	Key (x2)	

3 Operation Instruction

3.1 Installation Preparation

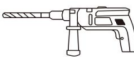
1) Tools required

Tool Name	Photo	Function
Multimeter		Check electrical connection and electrical parameter
Cross Screwdriver (PH2x150mm, PH3x250mm)		Tighten the screws
Insulated Torque Wrench		Tighten the bolts
Electric drill		Hole on the wall
Diagonal Pliers		Cut cables

2) Cables & Materials

Name	Specification	Quantity
Power supply cable(BK1)	EVE 3*10AWG+1*18AWG	1
Power supply cable(BK2)	EVE 3*9AWG+1*18AWG	1
Power supply cable(BK3)	EVE 2*8AWG+1*10AWG	1
Power supply cable(BK4)	EVE 2*8AWG+1*10AWG	1
Power supply cable(BK5)	EVE 2*6AWG+1*8AWG	1

3.2 Installation Process

1) Installation Notice

- Electrical devices should only be installed, operated, and maintained by qualified personnel. No responsibility is assumed by the manufacturer for any consequences arising out of the use of this device. A qualified person is one who has certified skills and knowledge related to the construction, installation and operation of this type of electrical device and who has received safety training to recognize and avoid the hazards involved.
- All applicable local, regional, and national regulations must be applied when installing, repairing and maintaining this device.
- RCD of the charger is intergrated 6mA DC, please install a Type A breaker outside.

2) Checks before starting the Installation Process

- Ensure the charger's location allows good operational access for normal use and repair & maintenance.
- The AC input components within the premise's power supply are correctly fitted with required protection items prior to installation of the charger.

3) Installation Foundation

1. Fix the foundation pier by pouring cement
2. Before completing the above steps, the input cable needs to be pre-buried below

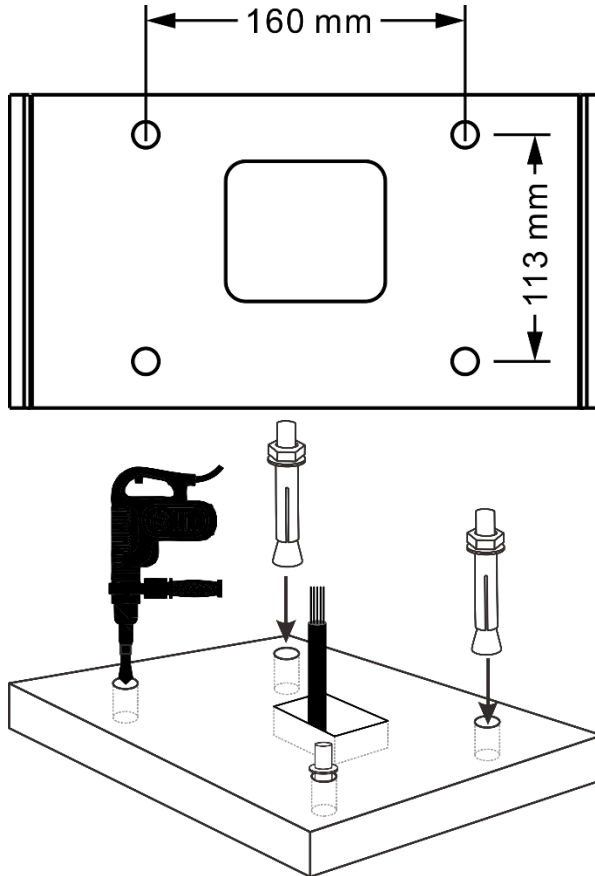

3. Fix the charging pile with screws (4*M8), and the input wire is connected to the input terminal of the charging pile

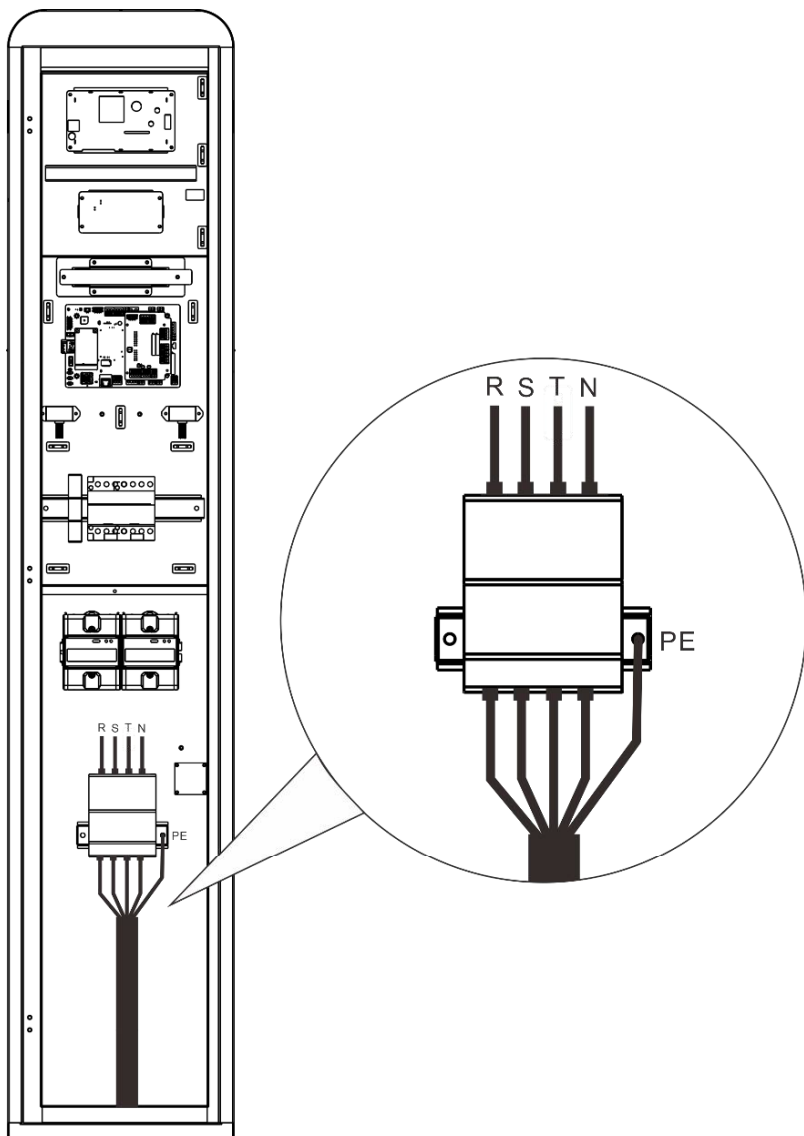

4. OPERATION

4.1 Power on

After the charging station has been installed and installation has been confirmed, the charging station switches to standby state, The display is shown in fig. 6-1.

Human-Machine Interface Overview

As shown in Fig. 6-1, the EMN series product is configured with multiple human-machine interfaces.

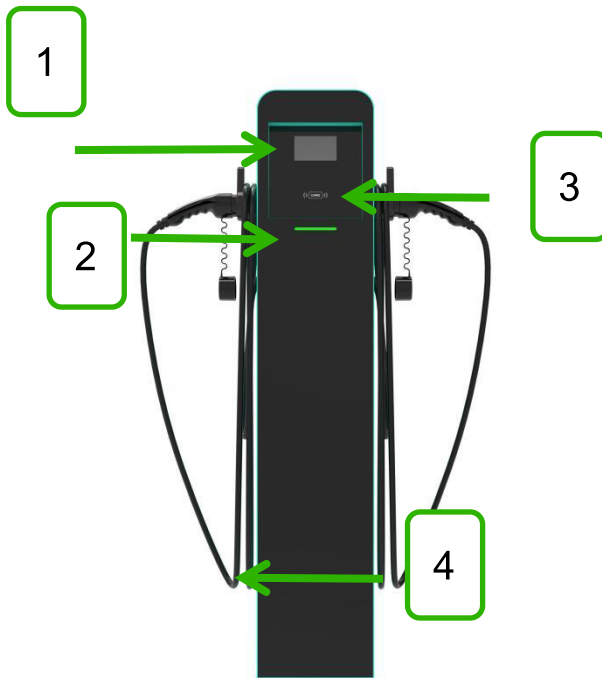

- 1 LCD Display
- 2 LCD
- 3 RFID
- 4 Type 2 GUN*2

Fig. 4-1 HMI of AC EV Charging Station

4.2 RGB LED indicator

Charger status	LED performance
Standby	blue (online)
plug in	yellow
swipe/punch a card	yellow
charging	Light green breath
Fault status	Red flashing

4.3 LCD indicators

the EMN series config a 5-inch LCD screen, which is mainly used to display various status information of the charging station, shown as Fig. 4-2.

Icons or instructions in each display area

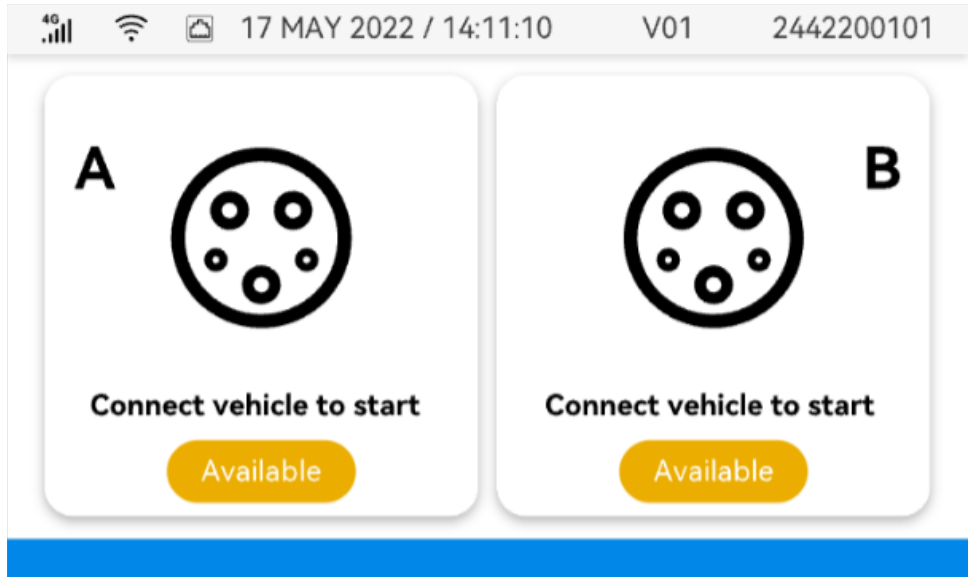





Fig. 4-2 Display of icons and instructions

the EMN series config a 5-inch LCD screen, which is mainly used to display various status information of the charging station, shown as Fig. 4-2.

No.	Icon	Description
Area ①		
1		Connected a network through 4G cellular
2		Connected a network through WIFI
3		Connected a network through Ethernet
Area ②		
4	QR code	Serial number of
Area ③		
5	status	status information
6	version	Software version

As shown in Fig. 6-3, 6-4, 6-5, 6-6, the LCD screen displays 4 types picture in normal state.



Fig. 6-3 Display of Preparing

Fig. 6-4 Display of Charging

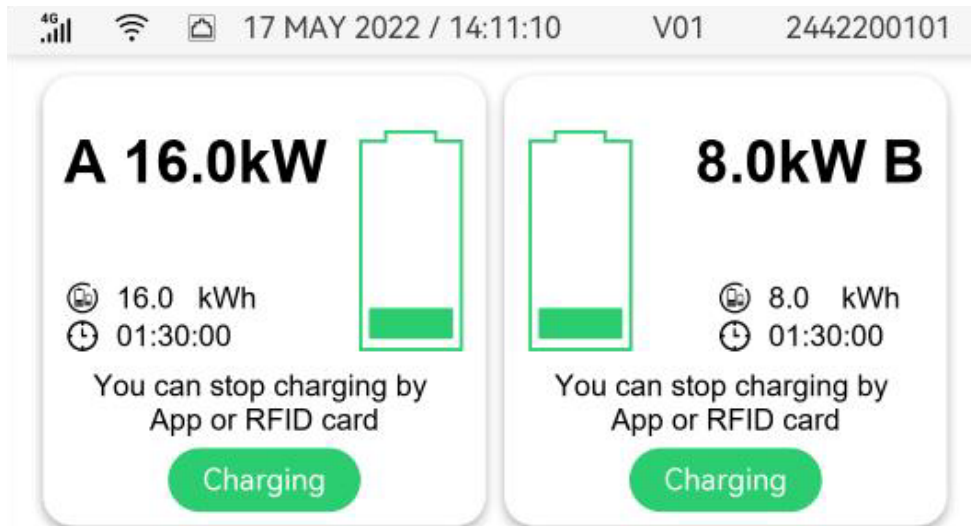

Fig. 6-5 Display of Charging

If the charging process fails or the equipment fails, the picture displayed on the LCD screen is shown in Fig. 6-6.

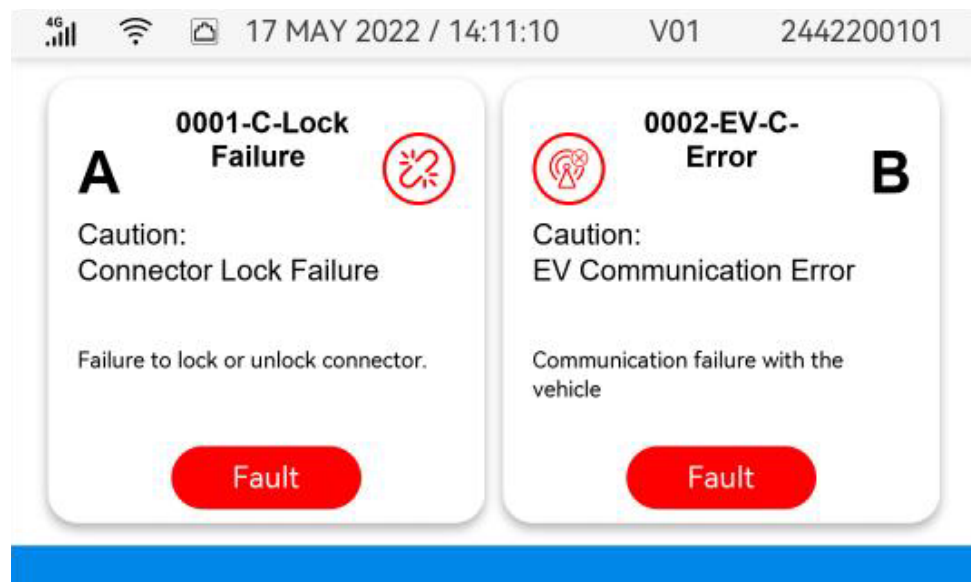

Fig. 6-6 Display of fault state

4.4 RFID reader

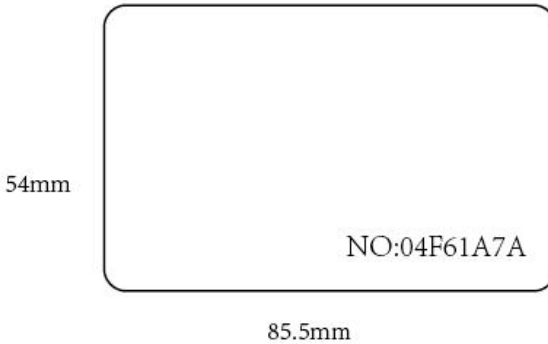

Fig. 6-7 RFID card

In general, the charging station is equipped with RFID card reader as standard, and the charging process can be started and stopped by using the RFID card (shown as Fig. 6-7) configured with the host. The special customized card swiping function is not separately described here

4.5 Emergency stop button

The button can stop or start charging after the device is configured to allow the button to start, The user can configure whether the function is enabled. See the 6.3 Configure parameters for details AC EV charging station config a type 2 charging connector. When the charging station is in standby state, please plug the charging connector into the empty socket in order to protect the charging connector.

4.6 Configure parameters(dynamic IP)

- Step1:** the same LAN router connect to with RJ45 line. shown as Fig. 6-9.
- Step2:** DIP switch to select dynamic IP, all dial to OFF. shown as Fig. 6-9.

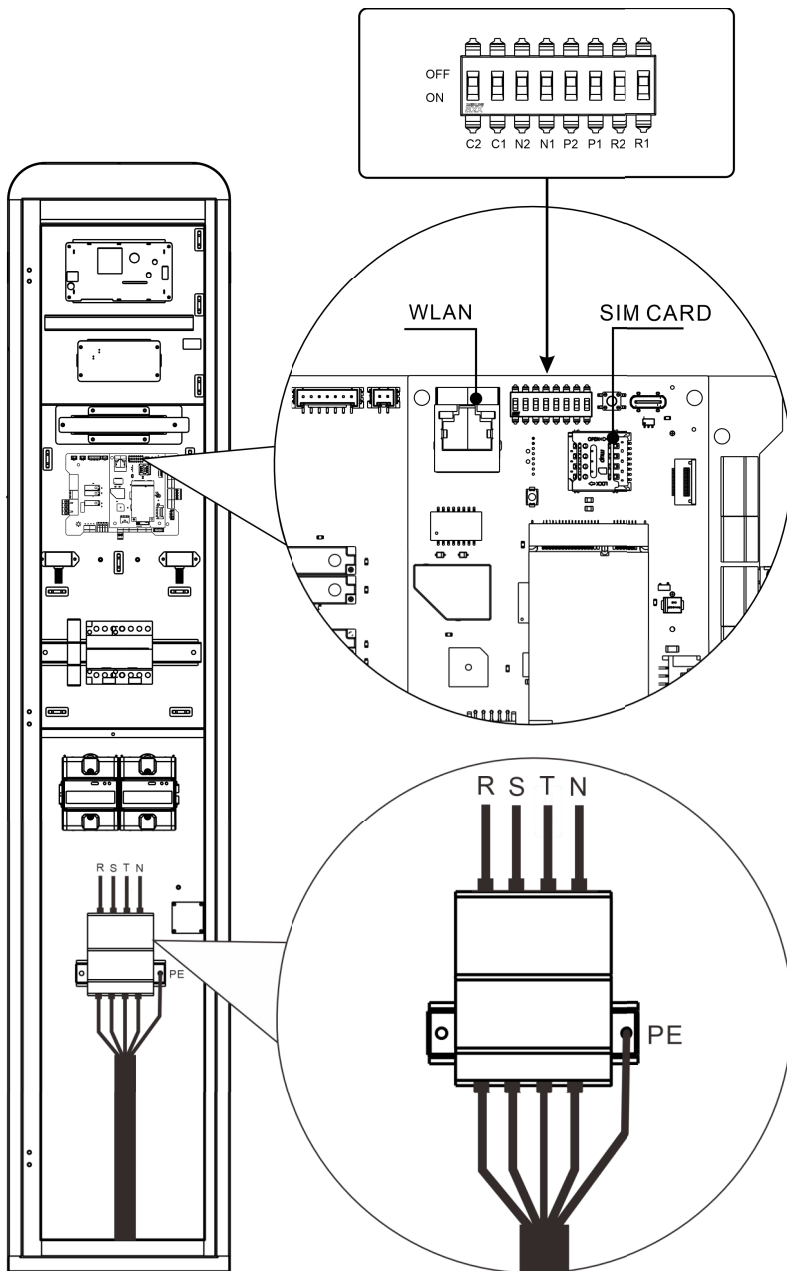

	ON	OFF	
C2	2 GUN	1 GUN	
C1	11KW	22KW	
N2		■	Ethernet DHCP
N1		■	
N2	■		WIFI
N1		■	
N2		■	4G
N1	■		
N2	■		Ethernet static
N1	■		
P2	Socket	Cable	
P1	Socket	Cable	
RCMU2	Enable	Disable	
RCMU1	Enable	Disable	

Fig. 6-9 Connect to WLAN with RJ45 line

Step 3: Login to the web interface

Enter **http://ocpp.local/login.html** in the address bar of Google Chrome or Microsoft Edge, you can access the CONFIGURATION shown below fig, and

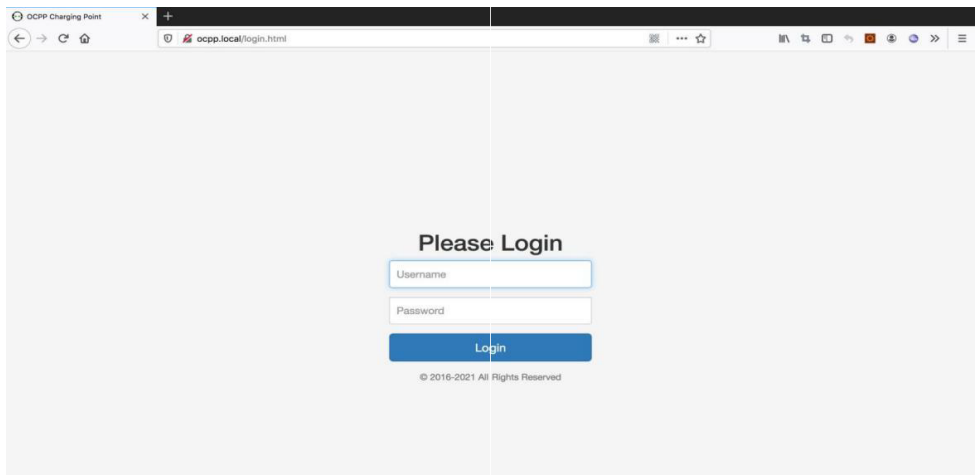

Microsoft IE cannot access this IP address.

Enter the correct login username and password to enter the page as shown UP fig. The username is root password is root@123456. As shown below fig, set the parameters on the "Configuration" page.

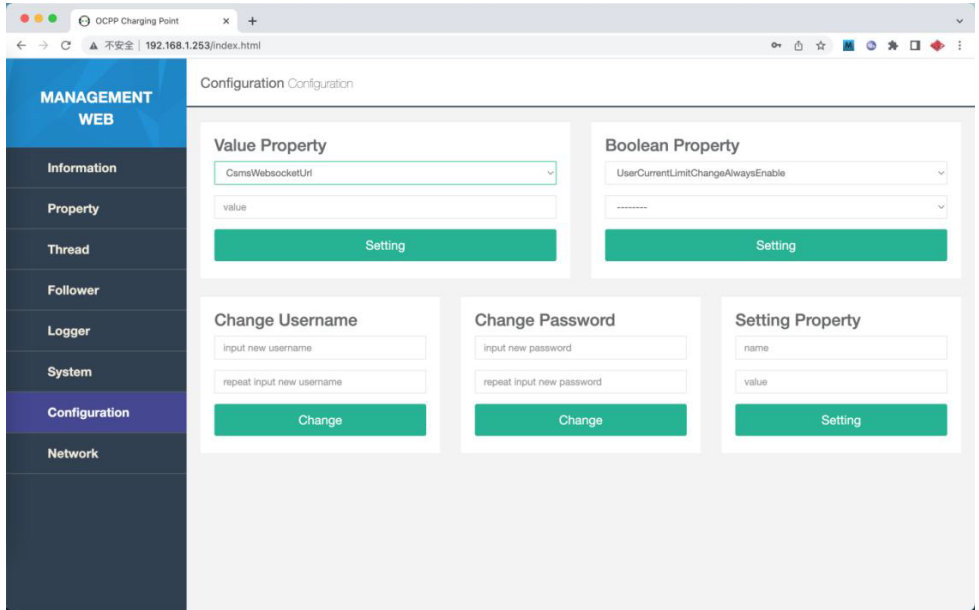

4.8 Configure parameters(static IP)

Taking the configuration of charging station parameters by laptop as an example, it is introduced as follows (the method of setting parameters by mobile phone is similar and will not be repeated):

- Step1:** Connect to with RJ45 line. shown as Fig. 6-9
- Step2:** DIP switch to select dynamic IP, all dial to ON. shown as Fig. 6-9
- Step3:** Keep your laptop in a state where it LAN use static IP 192.168.1.100, default gateway 192.168.1.253, network mask 255.255.255.0. Connect to the with RJ45 line. You should switch the board N1/N2 both to ON and reset the. By this setting the use a static IP 192.168.1.253. Now you can use **http://192.168.1.253** to login to the manage web.

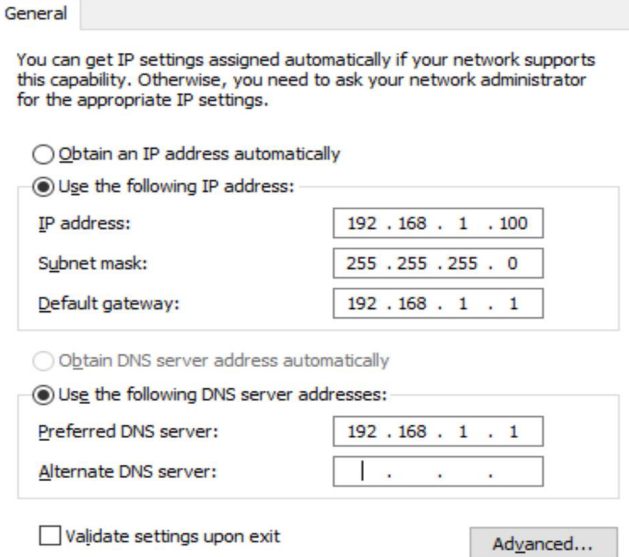

Fig. 6-10 Setting PC LAN network

Step4: Login to the web interface

Enter **http://192.168.1.253** in the address bar of Google Chrome or Microsoft Edge, you can access the ZECONEX CONFIGURATION shown in Fig. 6-11, and Microsoft IE cannot access this IP address. The username is root password is root@123456

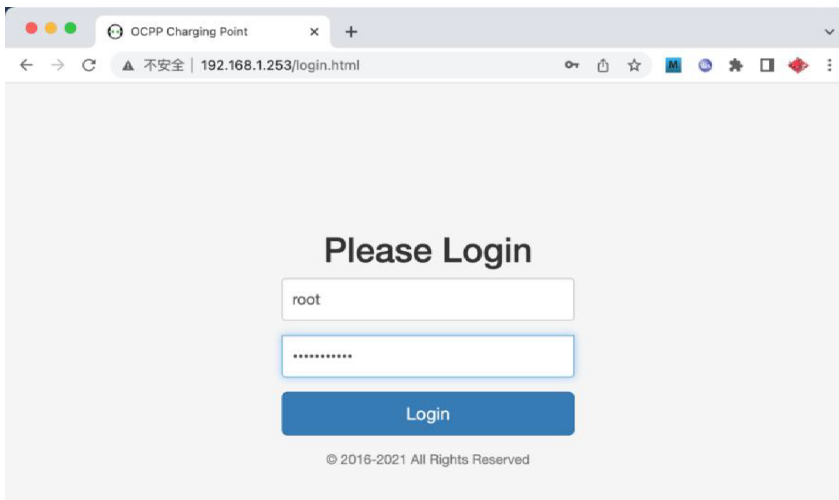

Fig. 6-11 Login of ZECONEX CONFIGURATION

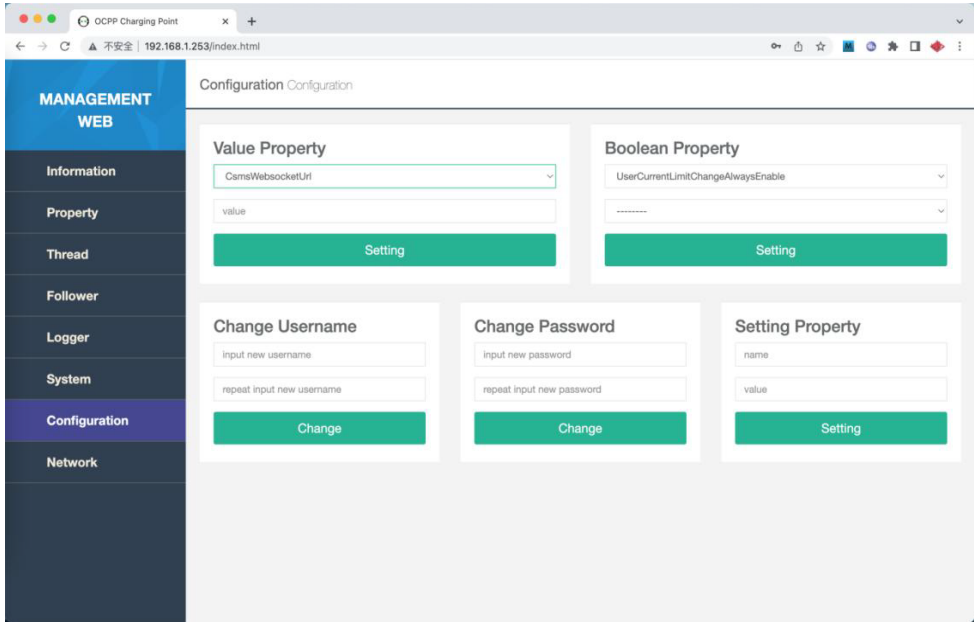

Fig. 6-12 Set parameters to config the EV charging station

After setting, click the “System” ---> “Reset Device” button to restart charging station for settings take effect.

4.9 Start Charging

Note: The vehicle to be charged must be parked, switched off and the parking brake engaged.

- a) Park your EV into place, turn off, and put the EV under braking.
- b) For tethered (cable) version: Remove the Type 2 cable from the plug holder of the ZECONE on the right side by pushing the button on the holder.
- c) For untethered (socket) version: Plug in the Type 2 plug of the charging cable into the ZECONE socket on the right side.
- d) As shown in Fig. 6-13, plug the charging connector into the AC charging socket of the EV, and the LED of the charging station lights yellow.
- e) For the mode of “Plug and play” charging station, the charging process will start automatically after plug in.

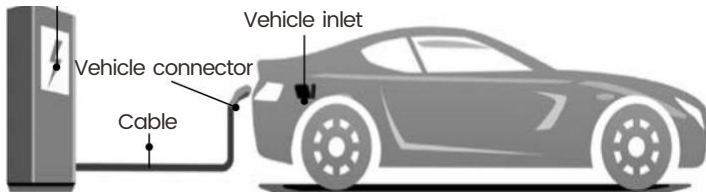

Fig. 6-13 Plug into EV

- f) For the mode of “swipe card” or “scan QR code” charging station, follow the instructions on the LCD screen after charging connector plug in, you can start charging process by swipe RFID card or scan QR code.

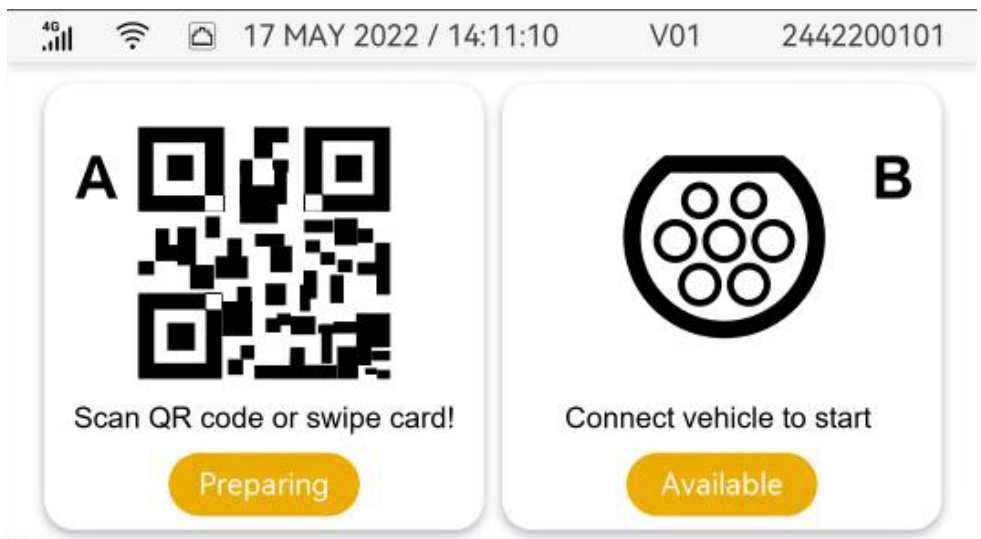

Fig. 6-14 Display of LCD screen after plug in

4.10 Normally stop charging

- a) The charging station will automatically stop when the electric vehicle is fully charged.
- b) For the mode of “plug-and-charge” charging station, you can manually stop charging as follow: press the unlock button of the remote key of the EV, the vehicle will stop charging (requires the support of the EV); if the charging does not stop, you may try to unplug the charging connector directly. When “Charging” indicator turns off, the charging process is end. For the mode of “swipe card” charging station, swipe your RFID card again, when “Charging” indicator turns off, the charging process is end.

- c) For the mode of "Scan QR code" charging station, click the stop button on your APP, the charging will stop.
- d) When the charging is end, please unplug the charging connector and plug back to the empty socket of charging station.

4.11 Normally stop charging

- a) Forced fault stop: A fault stop initiated by the onboard charger of vehicle.
- b) Automatic fault stop: A fault stop initiated by the charging station.

5. FAULT HANDLING AND MAINTENANCE

5.1 Fault Handling

The charging station is automatically protected in the event of the fault. The fault information and handling methods are as follows.

Fault information	LCD Show	Handling method
Ambient Temperature	<ul style="list-style-type: none"> • None 	<ul style="list-style-type: none"> • Check whether the power supply and distribution are normal; • Check whether the branch breaker is tripped, and close the breaker after troubleshooting; • Check whether the connection is correct, if the cable comes off, should be properly connected to tighten the cable.
Ambient Humidity	<ul style="list-style-type: none"> • EV Communication Error 	<ul style="list-style-type: none"> • Check that the adapter is properly connected to the electric vehicle, pull and plug the adapter and try charging again
Ambient Humidity	<ul style="list-style-type: none"> • E-stop 	<ul style="list-style-type: none"> • Check if ZECONEX is working properly and release emergency stop button by turning it around.

Fault information	LCD Show	Handling method
Under voltage fault	<ul style="list-style-type: none"> Under Voltage 	<ul style="list-style-type: none"> Check that the input cable is reliably connected, that the parent grid is properly connected, and that the grid voltage is abnormal.
Over voltage fault	<ul style="list-style-type: none"> Over Voltage 	<ul style="list-style-type: none"> Check whether the input cable is connected correctly; Whether the grid voltage is abnormal.
Over temperature fault	<ul style="list-style-type: none"> High Temperature 	<ul style="list-style-type: none"> Check whether the charging station is covered or installed in a high temperature environment.
Meter failure	<ul style="list-style-type: none"> Power Meter Failure 	<ul style="list-style-type: none"> Power off and restart the device
Leakage fault	<ul style="list-style-type: none"> Over DC 6MA 	<ul style="list-style-type: none"> Check whether the charging adapter and its cable are damaged or wet. Recover after pulling out the adapter.
Over current fault	<ul style="list-style-type: none"> Over Current Failure 	<ul style="list-style-type: none"> Check whether the charging adapter is correctly connected to the car, and check whether the on-board charger is normal
No diode at vehicle end	<ul style="list-style-type: none"> EV Communication Error 	<ul style="list-style-type: none"> This car is not up to standard and cannot be recharged
Relay sticking fault	<ul style="list-style-type: none"> Power Switch Failure 	<ul style="list-style-type: none"> The device is damaged and needs to be returned to the factory for repair
Ground fault	<ul style="list-style-type: none"> Ground Failure 	<ul style="list-style-type: none"> The charging pile is not grounded, so the circuit needs to be tested

5.2 Maintenance

To ensure the long-term stable operation of the equipment, please maintain the equipment regularly (usually every month) according to the operating environment.

- a) The equipment is maintained by professionals.
- b) Check whether the equipment is well grounded and safe.
- c) Check whether there are potential safety hazards around the charging pile, such as whether there are high temperature, corrosion or inflammable and explosive articles close to the charging station.
- d) Check whether the join point of the input terminal is in good contact and whether there is any abnormality. Check whether other terminal points are loose.



We hereby declare, that this device carries the CE mark in accordance with the regulations and standards. It conforms with the fundamental requirements of the RED Directive 2014/53/EU.

EMC Directive 2014/30/EU, and the Low Voltage Directive 2014/35/EU. The full text of the EU declaration of conformity is available at the following internet address: www.zeconex.com

NOTE ON ENVIRONMENTAL PROTECTION



After the implementation of the European Directive 2012/19/EU in the national legal system, the following applies:

Electrical and electronic devices may not be disposed of with domestic waste. Consumers are obliged by law to return electrical and electronic devices at the end of their service lives to the public collecting points set up for this purpose or point of sale. Details of this are defined by the national law of the respective country. This symbol on the product, the instruction manual or the package indicates that a product is subject to these regulations. By recycling, reusing the materials or other forms of utilising old devices, you are making an important contribution to protecting our environment.